

# (VN) DUP362 / BATTERY POWERED PRUNING SHEARS

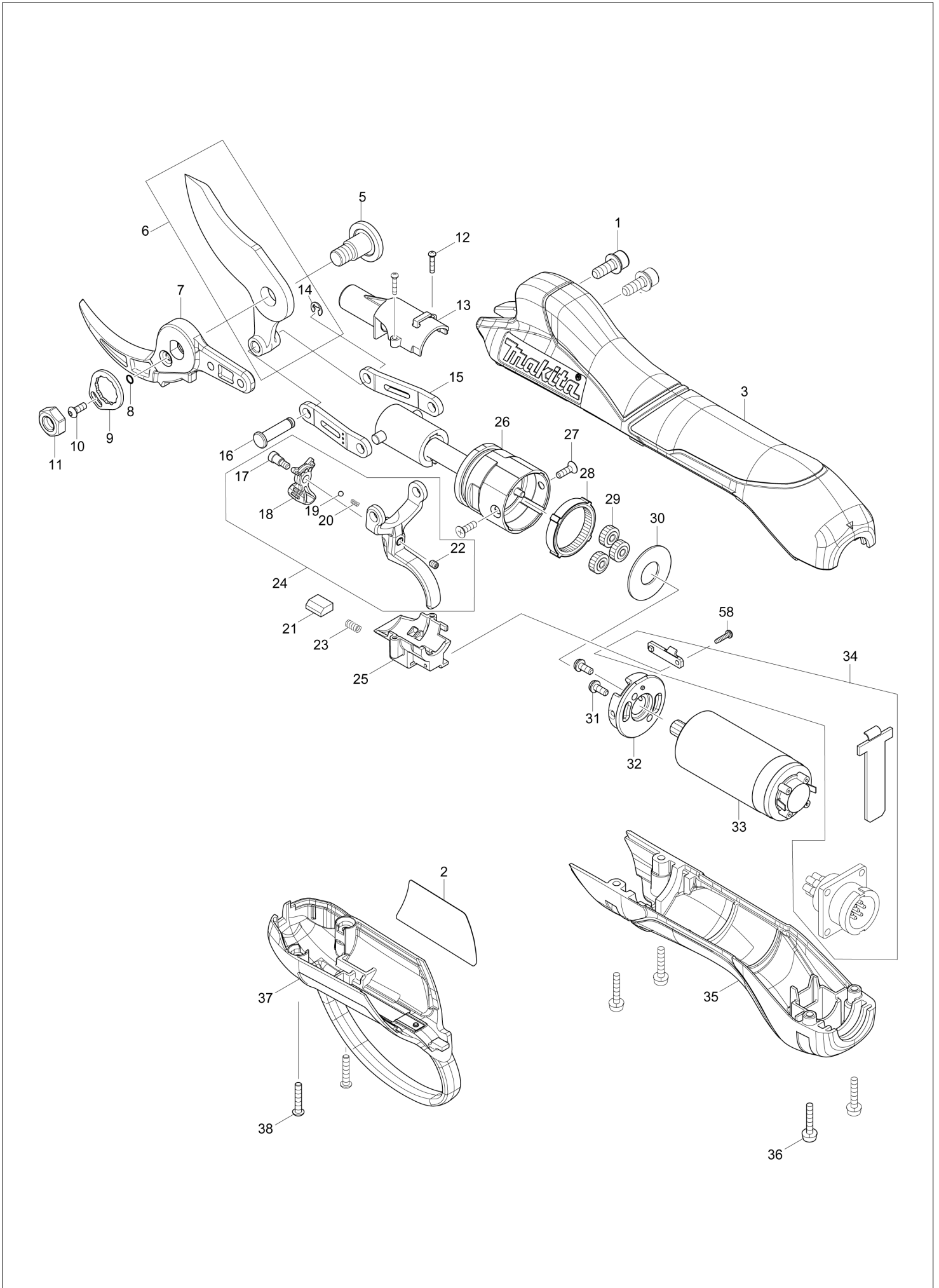

(VN) DUP362 / BATTERY POWERED PRUNING SHEARS

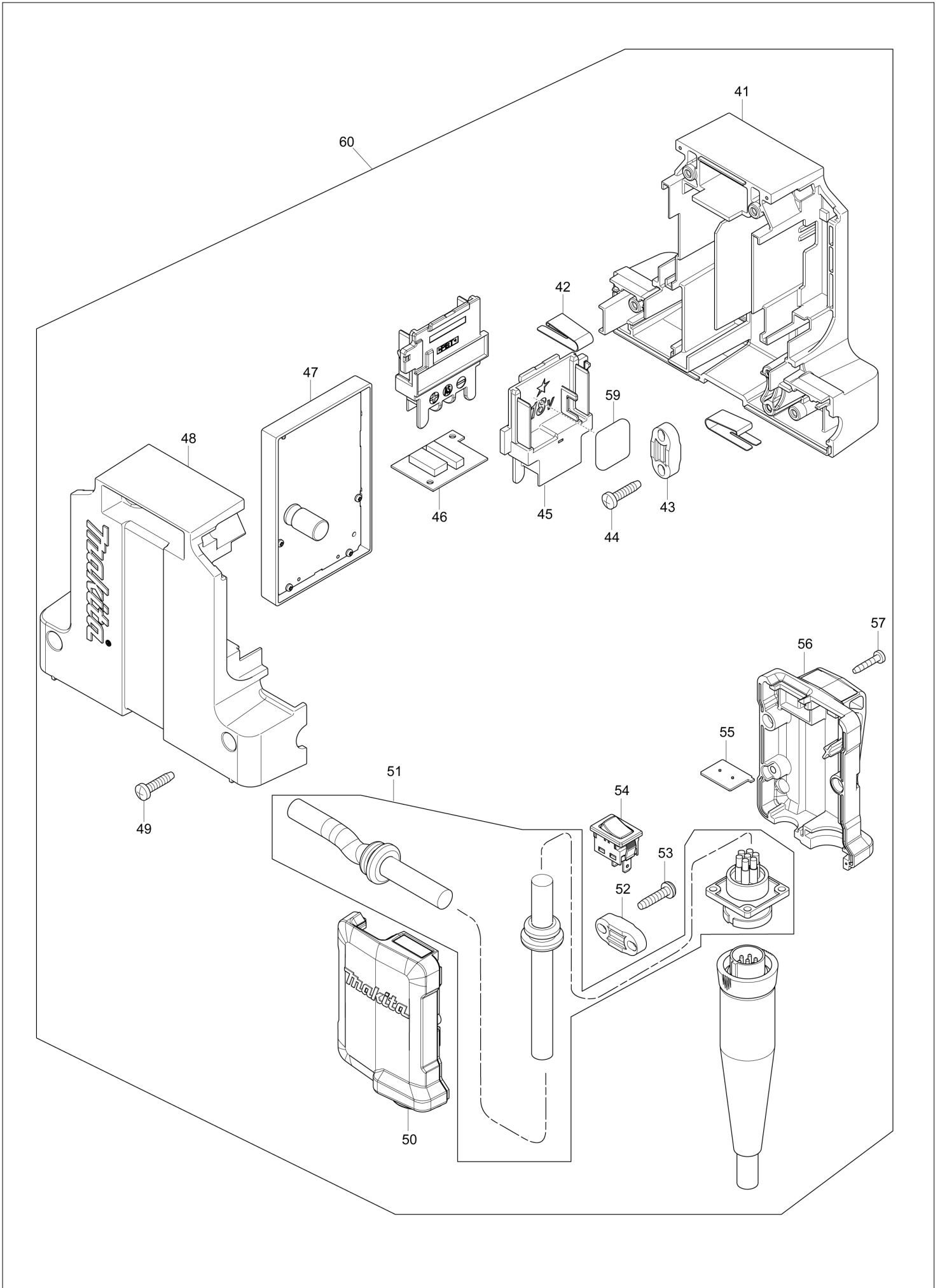

<b>VN</b>	<b>VIETNAM</b>
-----------	----------------

## DUP362 / BATTERY POWERED PRUNING SHEARS

Item	Sub	Parts No.	Parts Description	Qty	I/C	E/C No.	Close No.	Remark
001		251490-2	H.S.H.BOLT M5X14 WITH WR	2				
002		855F93-6	DUP362 NAME PLATE	1				
003		456209-6	UPPER HOUSING	1				
005		251474-0	SHOULDER SCREW M8	1				
006		199168-8	SHEAR BLADE U SET	1				
	D10		INC. 14					
007		199169-6	SHEAR BLADE L SET	1				
008		213034-6	O RING 3	1				
009		346940-1	LOCK PLATE	1				
010		266557-3	H.S.BUTTON HEAD BOLT M3X8	1				
011		264118-3	HEX. NUT M8	1				
012		266786-8	+ PAN HEAD TAPPING SCREW 2X10	2				
013		456218-5	BALL NUT COVER B	1				
014		961011-9	STOP RING E-4	1				
015		347165-0	LINK ARM	2				
016		256568-6	FLAT FILLISTER HD.PIN 5	1				
017		251484-7	+ FLAT HEAD SCREW M3X4	1				
018		456215-1	LEVER	1				
019		216031-1	STEEL BALL 2.3	1				
020		233491-2	COMPRESSION SPRING 2	1				
021		688189-0	MAGNET	1				
022		266999-1	H.S.SET SCREW(FLAT POINT)M3X4	1				
023		231397-8	COMPRESSION SPRING 4	1				
024		123536-3	TRIGGER ASS'Y	1				
	D10		INC. 17-20,22					
025		456217-7	BALL NUT COVER A	1				
026		127142-6	BALL SCREW ASSEMBLY	1				
027		912012-0	C.H.SCREW M3X10	2				
028		226866-2	INTERNAL GEAR 49	1				
029		226865-4	SPUR GEAR 19	3				
030		253810-6	FLAT WASHER 12	1				
031		911006-2	PAN HEAD SCREW M3X8	2				
032		319349-0	MOTOR HOLDER	1				
033		629397-4	DC MOTOR	1				
034		620459-1	SUB CONTROLLER	1				
035		456211-9	LOWER HOUSING	1				
036		911028-2	PAN HEAD SCREW M3X16	4				
037		143935-3	FRONT HOUSING COMPLETE	1				
	C10	807L80-7	INDICATION LABEL	1				
038		266980-2	HEX.S.BUTTON HEAD SCREW M3X16	2				
041		183B69-2	CONTROLLER HOUSING SET	1				
	D10		INC. 48					
042		232267-4	LEAF SPRING	2				
043		687053-2	STRAIN RELIEF	1				
044		265995-6	TAPPING SCREW 4X18	2				
045		643899-6	TERMINAL	2				
046		620461-4	RF UNIT	1				
047		620458-3	CONTROLLER	1				
048		183B69-2	CONTROLLER HOUSING SET	1				
	D10		INC. 41					
049		265995-6	TAPPING SCREW 4X18	4				
050		183B76-5	SWITCH HOUSING SET	1				
	C10	807E89-7	INDICATION LABEL	1				
	C20	807F74-6	CAUTION LABEL	1				
	D10		INC. 56					
051		699086-5	POWER SUPPLY CORD UNIT	1				
052		687053-2	STRAIN RELIEF	1				
053		265995-6	TAPPING SCREW 4X18	2				
054		651536-8	SWITCH 1941. 1451	1				
055		620460-6	LED CIRCUIT	1				
056		183B76-5	SWITCH HOUSING SET	1				
	C10	807E89-7	INDICATION LABEL	1				
	C20	807F74-6	CAUTION LABEL	1				
	D10		INC. 50					
057		266429-2	TAPPING SCREW 3X16	3				

B:DUP362PT2N(H)

Interchange  
O : Yes  
X : No  
< : the new part can be substituted for the current.  
> : the current part can be substituted for the new.  
S : Interchangeable as a set.

